

# How to Upgrade the Extreme Management Center to ExtremeCloud IQ – Site Engine version 21.4

**Abstract:** This document describes the necessary steps the admin should accomplish to upgrade the existing Extreme Management Center to the ExtremeCloud IQ – Site Engine.

**Published:** July 2021

Extreme Networks, Inc.  
145 Rio Robles  
San Jose, California 95134  
Phone / +1 408.579.2800  
Toll-free / +1 888.257.3000  
[www.extremenetworks.com](http://www.extremenetworks.com)

© 2012–2021 Extreme Networks, Inc. All Rights Reserved.

AccessAdapt, Alpine, Altitude, BlackDiamond, Direct Attach, EPICenter, ExtremeWorks Essentials, Ethernet Everywhere, Extreme Enabled, Extreme Ethernet Everywhere, Extreme Networks, Extreme Standby Router Protocol, Extreme Turbodrives, Extreme Velocity, ExtremeWare, ExtremeWorks, ExtremeXOS, Go Purple Extreme Solution, ExtremeXOS ScreenPlay, ReachNXT, Ridgeline, Sentiariant, ServiceWatch, Summit, SummitStack, Triumph, Unified Access Architecture, Unified Access RF Manager, UniStack, XNV, the Extreme Networks logo, the Alpinelogo, the BlackDiamond logo, the Extreme Turbodrives logo, the Summit logos, and the Powered by ExtremeXOS logo are trademarks or registered trademarks of Extreme Networks, Inc. or its subsidiaries in the United States and/or other countries.

sFlow is the property of InMon Corporation.

Specifications are subject to change without notice.

All other registered trademarks, trademarks, and service marks are the property of their respective owners.

For additional information on Extreme Networks trademarks, see [www.extremenetworks.com/company/legal/trademarks](http://www.extremenetworks.com/company/legal/trademarks).

## Table of Contents

---

<b>The sequence of necessary steps.....</b>	<b>3</b>
<b>Release Notes and documentation .....</b>	<b>4</b>
<b>Convert the Extreme Management Center licenses to subscriptions .....</b>	<b>5</b>
<b>Downloading upgrade binaries of ExtremeCloud IQ – Site Engine and components.....</b>	<b>6</b>
<b>Upgrade the Extreme Management Center to the ExtremeCloud IQ – Site Engine.....</b>	<b>8</b>
<b>Create a new ExtremeCloud IQ account.....</b>	<b>10</b>
<b>Upgrade ExtremeAnalytics &amp; ExtremeControl engines and Fabric Manager(s) and GIM(s) .....</b>	<b>12</b>
<b>Tuning and post-upgrade activities.....</b>	<b>13</b>
<b>Additional resources.....</b>	<b>14</b>

## The sequence of necessary steps

---

There are the following steps:

1. Read the Release Notes and related documentation.
2. Convert the perpetual licenses to the subscription-based entitlement. (The same procedure also applies for Extreme Management Center subscriptions.)
3. Download the upgrade binaries of Site Engine and components.
4. Upgrade the Extreme Management Center to the Site Engine.
5. Onboard the Site Engine to ExtremeCloud IQ. The Site Engine will consume entitlements from ExtremeCloud IQ.
6. Upgrade ExtremeAnalytics & ExtremeControl engines and Fabric Manager(s) and GIM(s)
7. Tuning and post-upgrade activities.

## Release Notes and documentation

---

- Read carefully the [Release Notes](#) there is a lot of important information.
- Check the new [licensing](#).
- Check what is Site Engine sending to ExtremeCloud IQ = [communication overview](#).
- Upgrade to Site Engine version 21.4.10.99 is supported from Extreme Management Center 8.5.5 and 8.4.4. More details [here](#).
- Check the [Hardware](#) and [Operating System](#) requirements.
- Follow the [pre-installation checklist](#).

## Convert the Extreme Management Center licenses to subscriptions

- The Site Engine requires Pilot or Navigator subscriptions.
- Subscriptions are consumed through connection to ExtremeCloud IQ.
- Contact the local Extreme Networks representative to transition from support contract model to subscription model. Typically, there is no additional cost for the transition. The procedure will require the following:
  - Fill the form with details
  - Run the workflow to calculate the appropriate number of Pilot & Navigator entitlements or export from the Extreme Management Center
  - Planned Upgrades or Expansion
  - Planned new Deployments and Hardware Refreshes
  - Existing service contracts (from the service team)
- When the license conversion procedure is finished:
  - The appropriate number of Pilot & Navigator entitlements are visible in the Extreme Portal.
  - The ExtremeCloud IQ can be linked to the Extreme Portal account.
  - The Site Engine can consume those entitlements through ExtremeCloud IQ.

### License Conversion

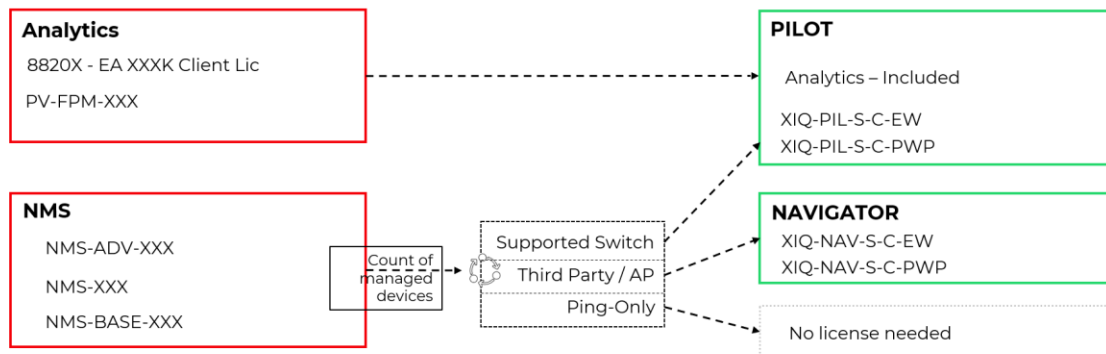

## Downloading upgrade binaries of ExtremeCloud IQ – Site Engine and components

1. Login to the [Extreme Portal](#)

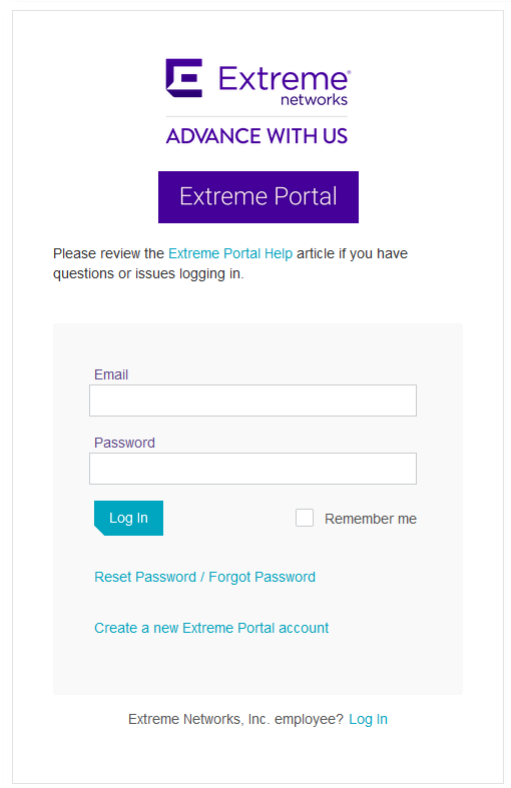

2. Select Products -> ExtremeCloud -> ExtremeCloud IQ – Site Engine

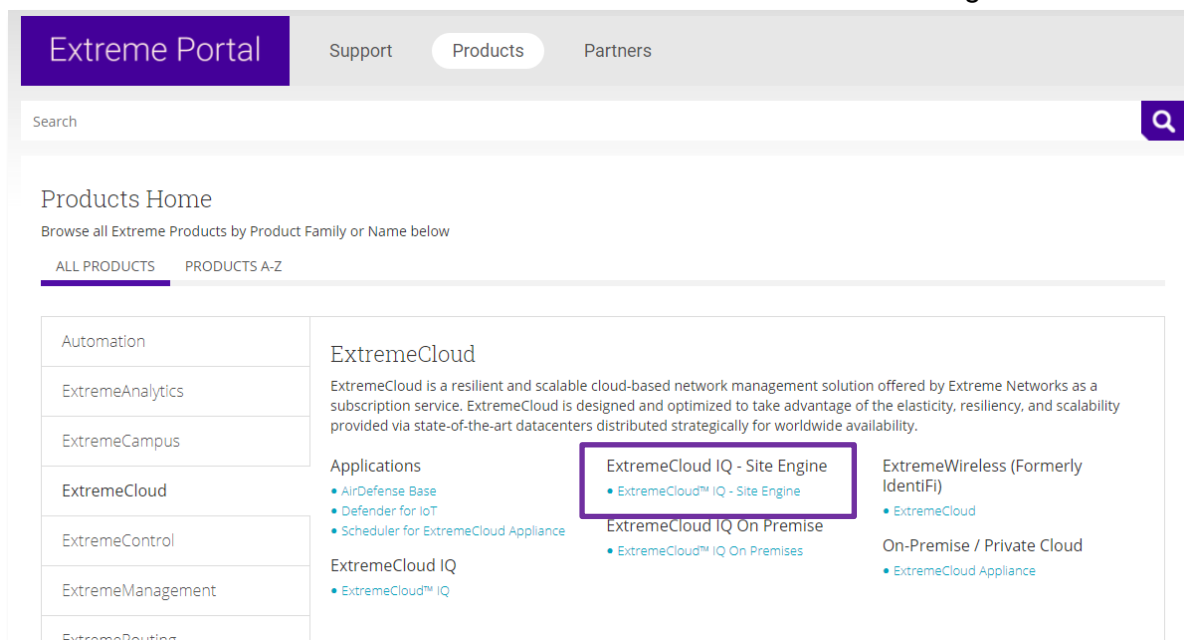

### 3. Select the version and the component (start with XIQ-SE)

Extreme Portal

Support Products Partners

Search

+ Automation  
+ ExtremeAnalytics  
+ ExtremeCampus  
- ExtremeCloud  
+ Applications  
+ ExtremeCloud IQ  
- ExtremeCloud IQ - Site Engine  
- ExtremeCloud™ IQ - Site Engine  
+ ExtremeCloud IQ On Premise  
+ ExtremeWireless (Formerly Identifi)  
+ On-Premise / Private Cloud  
+ ExtremeControl  
+ ExtremeManagement  
+ ExtremeRouting  
+ ExtremeSecurity  
+ ExtremeSwitching  
+ ExtremeWireless  
+ NetworkPacketBroker

## ExtremeCloud™ IQ - Site Engine

ExtremeCloud IQ - Site Engine, part of the ExtremeCloud IQ suite of products and services, is a cloud-connected, scalable SaaS management solution that provides you with task automation, access control, granular visibility with real-time analytics, and multi-vendor device management across your networks. ExtremeCloud IQ - Site Engine offers you all the features and functionality of Extreme Management Center, now with real-time flexibility and reduced time-to-benefit, all for the convenience and low cost of one license application.

SOFTWARE / RELEASE NOTES DOCUMENTATION

License Dependency

### Software & Downloads

Download / Release Name	File Size	Release Type	Release Date	EOVM Date	Tags	Link
<a href="#">21.04.10.99.Analytics</a>		Major	18.5.2021			
<a href="#">21.04.10.99.Control</a>		Major	18.5.2021			
<a href="#">21.04.10.99.Fabric Mgr</a>		Major	18.5.2021			
<a href="#">21.04.10.99.XIQ-SE</a>		Major	18.5.2021			

### Release Notes

Name	File Size	Release Date
<a href="#">XIQ-SE 21.04.10.99 Release Notes</a>	1.49 MB	18.5.2021

### 4. Download the upgrade BIN file

## Upgrade the Extreme Management Center to the ExtremeCloud IQ – Site Engine

1. Make a [backup](#) of your Extreme Management Center.
2. Connect to the console of the Site Engine and check the connectivity:

```
wget https://extremecloudiq.com
```

The success should look like this:

```
WWW Site:      http://www.extremenetworks.com
Support Email: support@extremenetworks.com
Phone:        800-998-2408

*****
root@xmc.extr.local:~$ wget https://extremecloudiq.com
--2021-06-01 18:36:11-- https://extremecloudiq.com/
Resolving extremecloudiq.com (extremecloudiq.com)... 34.253.190.220, 34.253.190.221
Connecting to extremecloudiq.com (extremecloudiq.com)|34.253.190.220|:443... connect
ed.
HTTP request sent, awaiting response... 302
Location: https://extremecloudiq.com/login [following]
--2021-06-01 18:36:11-- https://extremecloudiq.com/login
Reusing existing connection to extremecloudiq.com:443.
HTTP request sent, awaiting response... 200
Length: 6105 (6.0K) [text/html]
Saving to: 'index.html'

index.html      100%[=====>]      5.96K  --.-KB/s   in 0s

2021-06-01 18:36:11 (858 MB/s) - 'index.html' saved [6105/6105]

root@xmc.extr.local:~$ █
```

3. If the DNS and/or Gateway need to be changed then execute:  

```
dnetconfig
```
4. Upload the upgrade binary to the operating system (e.g. through SCP)
5. Follow the installation procedure in the [documentation](#). Answer questions required by the wizard.
6. Once the installation is completed navigate your web browser to **<https://<IP-of-your-server>:8443>** and login with your original Extreme Management Center credentials.
7. Accept the License Agreement
8. [Onboard](#) the Site Engine to ExtremeCloud IQ by providing the ExtremeCloud IQ credentials.



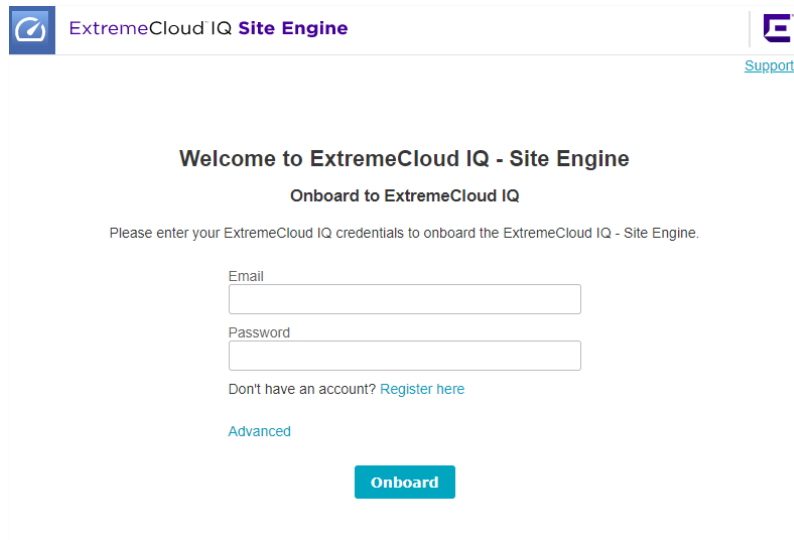

The screenshot shows the onboarding interface for ExtremeCloud IQ Site Engine. At the top left, there is a logo and the text "ExtremeCloud IQ Site Engine". At the top right, there is a logo and a "Support" link. The main heading is "Welcome to ExtremeCloud IQ - Site Engine" followed by "Onboard to ExtremeCloud IQ". Below this, a message says "Please enter your ExtremeCloud IQ credentials to onboard the ExtremeCloud IQ - Site Engine." There are two input fields: "Email" and "Password". Below the password field, there is a link "Don't have an account? Register here" and a link "Advanced". At the bottom center, there is a blue "Onboard" button.

These credentials are not stored, it is used only once for onboarding Site Engine to the ExtremeCloud IQ. If the onboarding is successful then skip the next chapter and continue there.

If the new ExtremeCloud IQ account is needed then click **Register here** and follow the instructions in the next chapter.

## Create a new ExtremeCloud IQ account

The Site Engine can not onboard to Connect level account.

The Site Engine requires a minimum of the Pilot level account.

1. Fill the [form](#), check your mailbox and create a password based on instructions in the email.
2. Login to the ExtremeCloud IQ with your new credentials
3. There are the following options:

- Select “I have an ExtremeCloud IQ license“ to link the ExtremeCloud IQ to the Extreme Portal. For the next question click NO if there is no legacy entitlement key:

Login to Extreme Portal to link the ExtremeCloud IQ account to the Extreme Portal

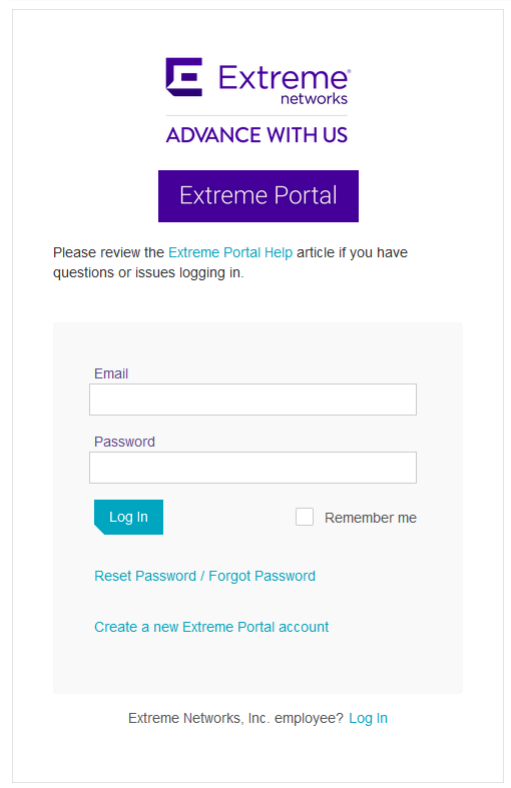

The image shows a screenshot of the Extreme Networks Portal login page. At the top, there is the Extreme Networks logo and the tagline "ADVANCE WITH US". Below this is a purple button labeled "Extreme Portal". A message asks the user to review the "Extreme Portal Help" article if they have questions or issues logging in. The login form includes fields for "Email" and "Password", a "Log in" button, and a "Remember me" checkbox. There are also links for "Reset Password / Forgot Password" and "Create a new Extreme Portal account". At the bottom, there is a link for "Extreme Networks, Inc. employee? Log In".

Now the subscription entitlements are available in your ExtremeCloud IQ and the ExtremeCloud IQ is ready for onboarding of the Site Engine.

## Upgrade ExtremeAnalytics & ExtremeControl engines and Fabric Manager(s) and GIM(s)

---

- Once the server is running the Site Engine, the ExtremeAnalytics Engine (Purview) needs to be upgraded. There are two options:
  - Upload the install binary to the Site Engine firmware repository and execute the upgrade of the Analytics Engine through the GUI. In this scenario, the SSH credentials must be configured and working.
  - Upload the install binary to the Analytics Engine and start the upgrade procedure through the console.
- The Access Control Engine upgrade procedure is similar to the Analytics Engine. There are two options:
  - Upload the install binary to the Site Engine firmware repository and execute the upgrade of the Control Engine through the GUI. In this scenario, the SSH credentials must be configured and working.
  - Upload the install binary to the Access Control Engine and start the [upgrade procedure](#) through the console.
- There are two options for the Fabric Manager upgrade procedure:
  - Upload the install binary to the Site Engine firmware repository and execute the upgrade of the Fabric Manager through the GUI. The Fabric Manager will be upgraded through the Cloud Connector.
  - Deploy and onboard the new Fabric Manager
- The GIM can be upgraded by deploying the new VM and connecting it to the Access Control Engines. The backup and restore feature of the GIM can be used.

## Tuning and post-upgrade activities.

- Devices that do not have serial numbers or MAC addresses in the Extreme Management Center must be Rediscovered after the upgrade to Site Engine before they can be onboarded to ExtremeCloud IQ.
- Check the [XIQ Onboarded](#) column in the Device Grid.
- The ExtremeCloud IQ is evaluating license usage, if the number of devices exceeds your available licenses, then Site Engine transitions to a license violation state, and your access to Site Engine features and functionality is locked. To resolve the license shortage, you need to access the Extreme Networks portal or ExtremeCloud IQ to evaluate the quantities of available Pilot and Navigator licenses versus the number of licenses required by Site Engine. There is an option to [Unmanage](#) Devices in ExtremeCloud IQ:

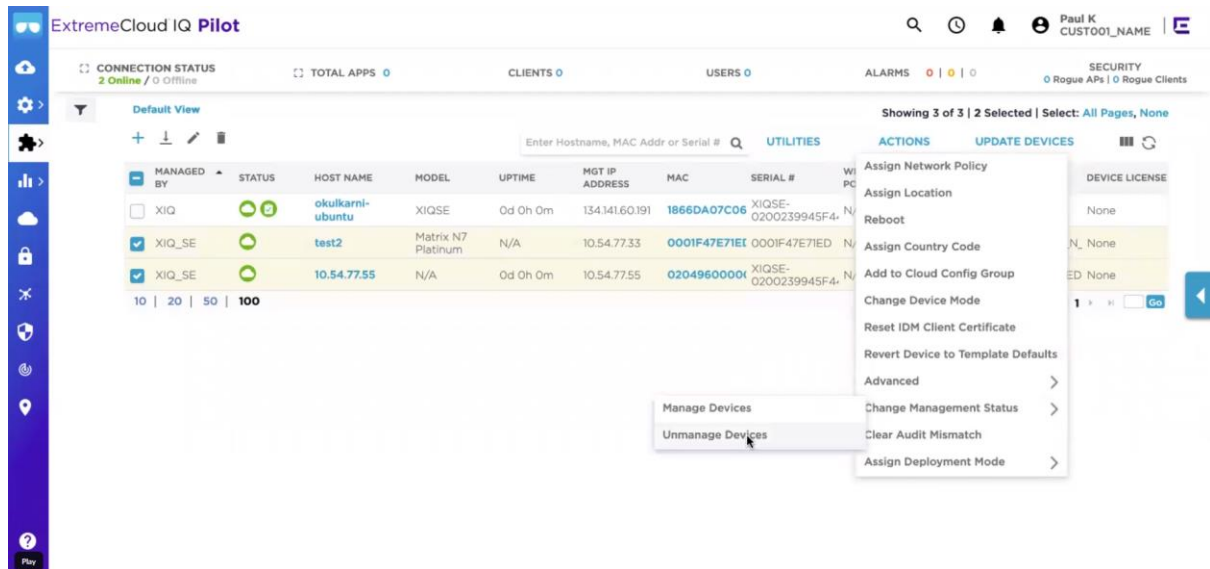

## Additional resources

---

User Guide online:

<https://emc.extremenetworks.com/>

User Guide for offline use:

[https://documentation.extremenetworks.com/netsight/XIQ-SE/XIQSE\\_21.04.10\\_User\\_Guide.pdf](https://documentation.extremenetworks.com/netsight/XIQ-SE/XIQSE_21.04.10_User_Guide.pdf)

Installation Guide online:

[https://emc.extremenetworks.com/content/oneview/install/suite\\_install.html](https://emc.extremenetworks.com/content/oneview/install/suite_install.html)

Installation Guide for offline use:

[https://documentation.extremenetworks.com/netsight/XIQ-SE/XIQSE\\_21.04.10\\_Installation\\_Guide.pdf](https://documentation.extremenetworks.com/netsight/XIQ-SE/XIQSE_21.04.10_Installation_Guide.pdf)

Firewall settings:

[https://emc.extremenetworks.com/content/oneview/r\\_used\\_ports.html](https://emc.extremenetworks.com/content/oneview/r_used_ports.html)

Release Notes:

<https://www.extremenetworks.com/support/release-notes/>